

XT5 Aerator Quick Tip



XT5 Aerator Preventative Maintenance

WHAT? Daily and Weekly preventative maintenance checklist for the TurnAer XT5 aerator.

WHY? Preventative Maintenance

Daily Preventative Maintenance

Daily Cleaning – Remove the weight tray and clean the tines of any cores and debris. Avoid using a high pressure wash

Check the oil level – Ensure that the engine is sitting level when checking the oil (**FIGURE 1**)

	Mon	Tues	Wed	Thurs	Fri	Sat	Sun
Cleaned							
Oil Checked							

Weekly Preventative Maintenance

Greasing – Lube the 2 grease fittings on the XT5. One on each transport wheel (**FIGURE 2a**)

Chain tension – Check tension on each side of the XT5. There should be an up and down movement of the chain between 1/2"-3/4". If more tension is needed loosen the idler sprocket and move it along the slot to add tension (**FIGURE 2b**).

Transaxle Belt inspection – Inspect the v-belt for wear, damage, or debris build-up. Clean if necessary then check for tension. Add tension with the idler pulley by loosening the pulley nut and sliding it along the slot. A 1/4" v-belt deflection on the longest run of the belt is the correct tension (**FIGURE 3**).

	Mon	Tues	Wed	Thurs	Fri	Sat	Sun
Greasing							
Belt Inspection							
Chain Tension							

Completed by:

Serial Number _____ Name _____ Signature _____ Date _____

This Quick Tip is only a guide, always refer to your Operators Manual



FIGURE 1: Level engine for proper oil check. This picture uses 2 2x4's under the front tires to level the engine.

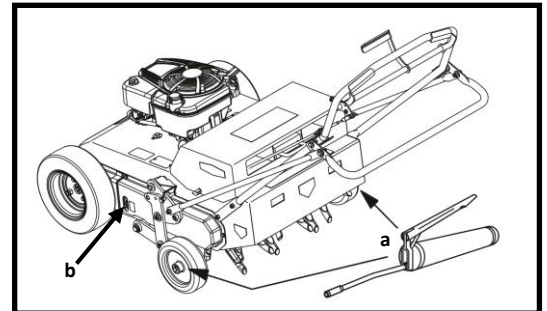

FIGURE 2: a) Grease fittings b) Locations of idler sprocket for chain tension. Other location is the opposite side of the machine

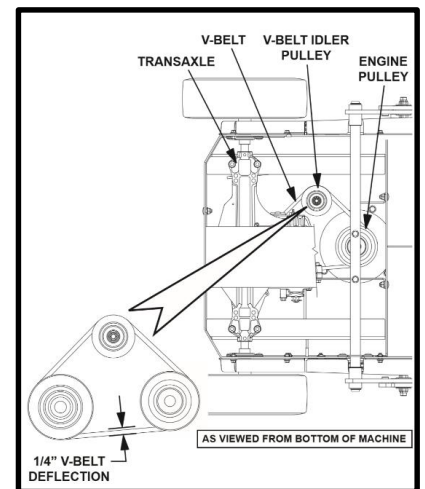

FIGURE 3: V-Belt Pulley location and tension check